

POPULAR OPTIONS

- Standard loading ramp for pallet jack
- Extended heavy duty ramp for electrical walkie
- Wrap height extension for taller pallets
- Frame extension for larger than standard pallets
- Turntable surround deck for pit mounting
- Scale package with digital weight indicator
- Auto film cut
- 30" film carriage
- 70" diameter turntable

SPECIFICATIONS

- Turntable Speed: Adjustable up to 16 RPM
- Control Type: Full-Feature Semi-Automatic
- Max. Load Capacity: 5,000 lbs
- Max. Load Height: 86"
- Turntable Size: 59" diameter
- Turntable height: 3" from floor
- Pre-Stretch ratio: 250% standard
- Max. Load Size: 56" x 56"
- Electrical: 115/1/60 15 amp
- Warranty: 3/5 years limited
- Tower Height: 85"
- Clearance Required: 97"

Sonic LPX Low Profile Semi-Automatic

The X-STRETCH pre-stretch film carriage provides superior filmeconomy, filmtension and user safety.

The Robust PRO-GLIDE turntable support system is maintenance free and features superior weight capacity.

The advanced and user-friendly DIGI-TECH control unit features unique functions to wrap any type of pallet .



FEATURES

- Uses 20" machine film
- Electronically adjustable film tension
- 250 % film pre-stretch ratio, others available
- Maintenance free ball bearing carriage guide
- Automatic corner compensation
- Lifetime warranty on stretch rollers
- Structural steel frame
- Forklift portable
- Very low maintenance
- Easy access to components
- ½ HP turntable drive motor
- Heavy duty turntable chain drive
- Maintenance free turntable support casters
- Photo-eye automatic height detection
- Separate top and bottom wrap count 1-10
- Turntable soft start/stop
- Dual adjustable film carriage speed
- Reinforce wrap function
- Positive turntable home alignment
- Gentle cycle feature for light or unstable pallets

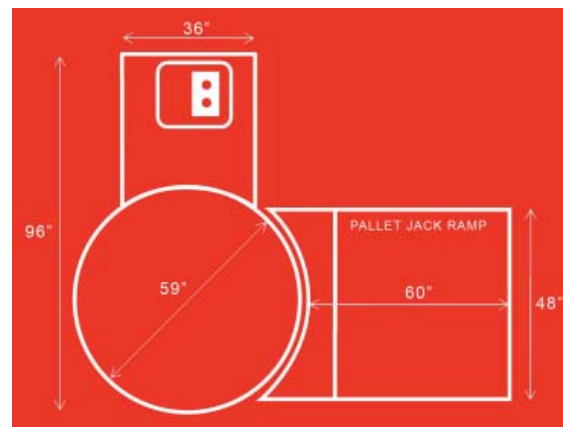
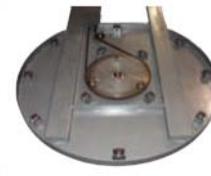

Plan View



Sonic LPA Low Profile Automatic

The X-STRETCH pre-stretch film carriage provides superior filmeconomy, filmtension and user safety.

The Robust PRO-GLIDE turntable support system is maintenance free and features superior weight capacity.

The advanced and user-friendly DIGI-TECH control unit features unique functions to wrap any type of pallet.



FEATURES

- Uses 20" machine film
- Electronically adjustable film tension
- 250 % film pre-stretch ratio, others available
- Maintenance free ball bearing carriage guide
- Automatic corner compensation
- Lifetime warranty on stretch rollers
- Structural steel frame
- Forklift portable
- Very low maintenance
- Easy access to components
- 1/2 HP turntable drive motor
- Heavy duty turntable chain drive
- Maintenance free turntable support casters
- Photo-eye automatic height detection
- Separate top and bottom wrap count 1-10
- Turntable soft start/stop
- Dual adjustable film carriage speed
- Reinforce wrap function
- Positive turntable home alignment
- Gentle cycle feature for light or unstable pallets

POPULAR OPTIONS

- Standard loading ramp for pallet jack
- Extended heavy duty ramp for electrical walkie
- Wrap height extension for taller pallets
- Turntable surround deck for pit mounting
- Scale package with digital weight indicator
- Remote start lanyard switch
- Safety guarding around wrap zone

SPECIFICATIONS

- Turntable Speed: Adjustable up to 16 RPM
- Control Type: Automatic
- Max. Load Capacity: 5,000 lbs
- Max. Load Height: 86"
- Turntable Size: 70" diameter
- Turntable height: 3" from floor
- Pre-Stretch ratio: 250% standard
- Max. Load Size: 50" x 50"
- Electrical: 115/1/60 15 amp
- Compressed Air: 3 CFM @ 80 PSI"
- Warranty: 3/5 years limited
- Tower Height: 85"
- Clearance Required: 97"

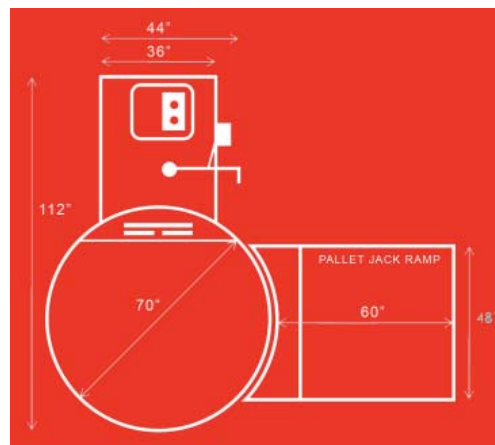

Plan View



Sonic LPS Low Profile Semi-Automatic

The X-STRETCH pre-stretch film carriage provides superior filmeconomy, filmtension and user safety.

The Robust PRO-GLIDE turntable support system is maintenance free and features superior weight capacity.

The advanced and user-friendly DIGI-TECH control unit features unique functions to wrap any type of pallet.



FEATURES

- Uses 20" machine film
- Electronically adjustable film tension
- 250 % film pre-stretch ratio, others available
- Maintenance free ball bearing carriage guide
- Automatic corner compensation
- Lifetime warranty on stretch rollers
- Structural steel frame
- Forklift portable
- Flush with floor pit mountable
- Easy access to components
- 1/2 HP turntable drive motor
- Heavy duty turntable chain drive
- Maintenance free turntable support casters
- Photo-eye automatic height detection
- Separate top and bottom wrap count 1-10
- Turntable soft start/stop
- Dual adjustable film carriage speed
- Reinforce wrap function
- Positive turntable home alignment
- Gentle cycle feature for light or unstable pallets

POPULAR OPTIONS

- Standard loading ramp for pallet jack
- Extended heavy duty ramp for electrical walkie
- Wrap height extension for taller pallets
- Frame extension for longer and wider pallets
- Scale package with digital weight indicator
- Auto film cut
- 30" film carriage
- 70" diameter turntable

SPECIFICATIONS

- Turntable Speed: Adjustable up to 16 RPM
- Control Type: Full-Feature Semi-Automatic
- Max. Load Capacity: 5,000 lbs
- Max. Load Height: 86"
- Turntable Size: 59" diameter
- Turntable height: 3" from floor
- Pre-Stretch ratio: 250% standard
- Max. Load Size: 56" x 56"
- Electrical: 115/1/60 15 amp
- Warranty: 3/5 years limited
- Tower Height: 85"
- Clearance Required: 97"

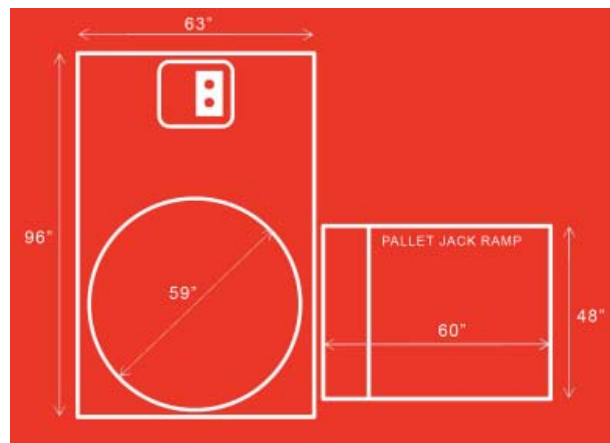

Plan View



Sonic HPX High Profile Semi-Automatic

The X-STRETCH pre-stretch film carriage provides superior filmeconomy, filmtension and user safety.

The Robust PRO-GLIDE turntable support system is maintenance free and features superior weight capacity.

The advanced and user-friendly DIGI-TECH control unit features unique functions to wrap any type of pallet.



FEATURES

- Uses 20" machine film
- Electronically adjustable film tension
- 250 % film pre-stretch ratio, others available
- Maintenance free ball bearing carriage guide
- Automatic corner compensation
- Lifetime warranty on stretch rollers
- Structural steel frame
- Forklift portable from front and rear
- Very low maintenance turntable drive
- Easy access to components
- 1/2 HP turntable drive motor
- Heavy duty turntable chain drive
- Heavy duty turntable support casters
- Photo-eye automatic height detection
- Separate top and bottom wrap count 1-10
- Turntable soft start/stop
- Dual adjustable film carriage speed
- Reinforce wrap function
- Positive turntable home alignment
- Gentle cycle feature for light or unstable pallets

POPULAR OPTIONS

- Wrap height extension for taller pallets
- Frame extension for larger than standard pallets
- Split base for variable pallet size
- Turntable weight capacity increase
- Scale package with digital weight indicator
- Auto film cut
- 30" film carriage
- 59" diameter turntable

SPECIFICATIONS

- Turntable Speed: Adjustable up to 16 RPM
- Control Type: Full-Feature Semi-Automatic
- Max. Load Capacity: 5,000 lbs
- Max. Load Height: 80"
- Turntable Size: 48" x 48" octagonal
- Turntable height: 9" from floor
- Pre-Stretch ratio: 250% standard
- Max. Load Size: 56" x 56"
- Electrical: 115/1/60 15 amp
- Warranty: 3/5 years limited
- Tower Height: 85"
- Clearance Required: 97"

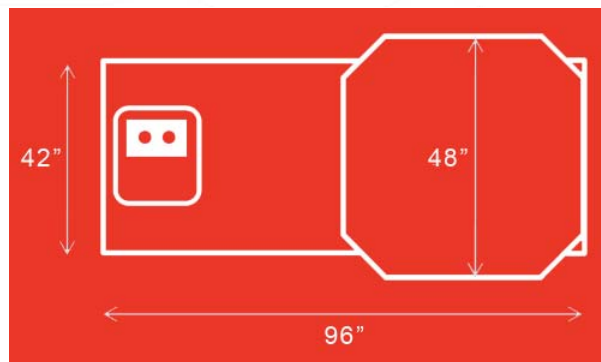

Plan View