

CAM SINGULATOR SYSTEM



FEATURES

- Mixed/assorted, multi-packs, or single flavour—one system
- Kit building (Variety/Assorted Packs)
- Single to large counts same machine
- On-demand assorted packages
- Package placement confirmation
- Full color, user-friendly HMI and controls
- No package—no count
- Ergonomic design
- Load hopper level control with warning lights
- Safety interlock dual channel guarding
- Stainless steel or food-grade approved materials for all contact surfaces
- Small footprint
- User-friendly operator controls
- Modular design to expand as needed
- Designed and built in North America
- Database communication and matching
- Remote connections for online ordering
- Selective feeding configuration



CAM 6 Lane Singulator

- Can be integrated over a CAM premade or VFFS bagging machine while having the option to change to a box or carton quickly
- In production mode we can fill your retail package; in e-commerce mode packages are created as required



CAM 20 Lane Singulator

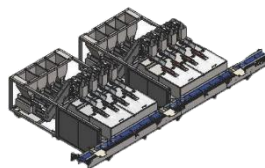

CAM 8 Lane Singulator

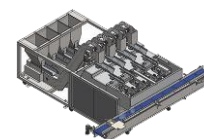

CAM 4 Lane Singulator

CAM SINGULATOR

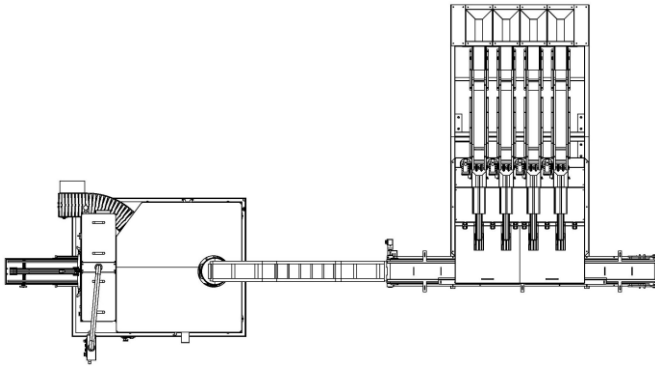

Singulator feeding into a premade

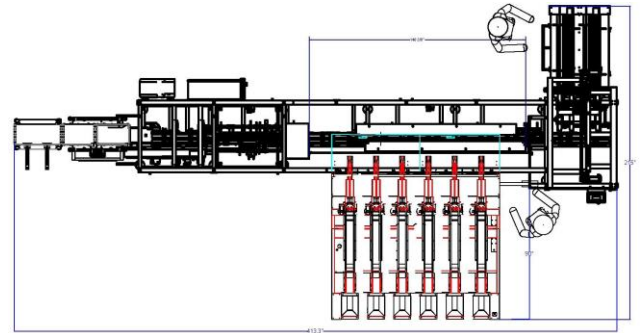

Singulator integrated with a cartoner

OPERATING SEQUENCE

STEP # 1
Bulk filling of large hopper

STEP #2
Separate product

STEP #3
Count individual product

STEP #4
Grouping product in desired count

STEP #5
Release group/count to:

- a) packaging media
- b) pocketed conveyor
- c) integrated into auxiliary equipment

OPTIONS

- Quick change feed hopper
- Quick change count conveyor
- Checkweigher with reject system
- Allen Bradley control platform
- Custom design package conveyor for smooth feeding directly into packaging media
- Bagging equipment
- Automatic package feeding solutions
- Monitoring diagnostics with remote access

POSSIBLE CONFIGURATIONS

- Any combination of lanes per system
- 4 lanes on a single portable frame
- Can be configured to have 24 or greater Singulator feeding lanes